

Inhaltsverzeichnis

Table of Contents

4	Antriebssystem für elektrische Aufzüge	4	<i>Gear systems for electrical elevator</i>
	Auswahltabellen		<i>Selection tables</i>
	Stirnrad-Schneckengetriebe, Aufhängung 1:1		<i>Spur-worm gear, suspension 1:1</i>
5	Nutzlast Q = 320 ... 630 kg	5	<i>Payload Q = 320 ... 630 kg</i>
6	Nutzlast Q = 800 ... 2500 kg	6	<i>Payload Q = 800 ... 2500 kg</i>
	Schnecken-Stirnradgetriebe, Aufhängung 1:1		<i>Worm-spur gear, suspension 1:1</i>
7	Nutzlast Q = 320 ... 1000 kg	7	<i>Payload Q = 320 ... 1000 kg</i>
	Stirnrad-Schneckengetriebe, Aufhängung 2:1		<i>Spur-worm gear, suspension 2:1</i>
8	Nutzlast Q = 320 ... 1250 kg	8	<i>Payload Q = 320 ... 1250 kg</i>
9	Nutzlast Q = 1600 ... 5000 kg	9	<i>Payload Q = 1600 ... 5000 kg</i>
	Schnecken-Stirnradgetriebe, Aufhängung 2:1		<i>Worm-spur gear, suspension 2:1</i>
10	Nutzlast Q = 320 ... 1600 kg	10	<i>Payload Q = 320 ... 1600 kg</i>
11	Fragebogen zur Projektierung von Aufzugsantrieben	11	<i>Form for projection of elevator gear units</i>
	Abmessungen		<i>Dimensions</i>
12	SSMVD 80 ... 160	12	<i>SSMVD 80 ... 160</i>
14	SSMVD 250	14	<i>SSMVD 250</i>
16	SSTKVD 97 ... 150	16	<i>SSTKVD 97 ... 150</i>
18	Frequenzumrichter	18	<i>Frequency converter</i>
20	Auszug aus der Betriebsanleitung	20	<i>Extract from the operation instructions</i>
21	Betriebslagen	21	<i>Operating positions</i>
22	Berechnung der Treibscheibenwelle	22	<i>Calculation of traction sheave shaft</i>

Antriebssystem für elektrische Aufzüge

Gear systems for electrical elevator

Merkmale

- geeignet für maschinenraumlose und maschinenraum-behaftete Anwendungen
- elektromagnetische Doppelbremse, geräuschgedämpft, getrennt ansteuerbar, mit Handlüftung
- Schutzgrad IP 54
- hoher Wirkungsgrad aufgrund mehrgängiger Verzahnung, geringer Energieverbrauch, geräuscharm, kompakt und platzsparend

Lieferumfang

- Aufzugsantrieb komplett montiert mit Treibscheibe, Pendelrollenlager, Motor mit Doppelbremse und Inkrementalgeber
- abnahmerelevante technische Unterlagen und Betriebsanleitung

Option

- Bremse mit Überwachung (Mikroschalter)
- Handrad
- Treibscheibenklemme
- Geberkabel
- voreingestellter Frequenzumrichter inkl. SM-Keypad, Netzfilter, Bremswiderstand
- Option: • SM-Keypad plus
 - personalisierbar
 - Bedienung aus 30 m Entfernung (Kabel erforderlich)
 - Komfortsteuerung (SM Application lite)

Characteristics

- *suitable for applications with separate machining room operation and without machining room*
- *low noise electro-magnetic double brake, can be individually controlled with manual brake release*
- *degree of protection IP 54*
- *high level of efficiency due to multiple stage toothing, low energy consumption, low noise level, compact and space-saving*

Scope of delivery

- *elevator gear unit completely assembled with traction sheave, motor with dual brake and incremental encoder*
- *technical documents relevant to final inspection and operation instructions*

Option

- *brake with monitoring (microswitch)*
- *handwheel*
- *traction sheave clamp*
- *encoder cable*
- *pre-set frequency converter including SM key pad, line filter, brake resistor*
- Option: • *SM key pad plus*
 - *can be personalised*
 - *operating in 30 m distance (cable required)*
 - *convenience controls (SM application lite)*

Auswahltabelle / Selection table

Stirnrad-Schneckengetriebe

Spur-worm gear

Allgemeines

- Berechnung der Treibfähigkeit und Seilsicherheit gemäß EN 81
- Förderhöhe: max. 25 m
- Seilgewicht nicht ausgeglichen
- Umschlingungswinkel > 155°

Bremsmotor

- Betrieb am FU
- Spannung 3 x 400 V
- Inkrementalgeber 1024 Imp., TTL (Option: HTL, Sinus)
- Spulenspannung Bremse: 24 VDC (Option: 205 VDC)

Treibscheibe

- Härte: > 220 HB (Option: Treibscheibenrille gehärtet)

Bemerkung

Die nachfolgende Auswahltabelle dient lediglich für die Vorauswahl des Antriebes. Eine exakte Berechnung erfolgt nach Bekanntgabe der Anlagedaten. Bitte benutzen Sie das Formblatt „Fragebogen zur Projektierung von Aufzugsantrieben“ (Seite 11).

Aufhängung 1:1

Schachtwirkungsgrad = 84%
Schalldruckpegel in 1 m Abstand < 65 dB(A)
Geräuschmessung nach DIN 45635-23-KL3

General

- calculation in accordance with EN 81 for driving ability and rope safety
- travel height: max. 25 m
- without compensation rope
- arc of contact > 155°

Brake motor

- working with frequency converter
- voltage 3 x 400 V
- incremental encoder 1024 Imp., TTL (option: HTL, Sinus)
- rated voltage brake: 24 VDC (option: 205 VDC)

Traction sheave

- hardness: > 220 HB (option: grooves hardened)

Remark

The following selection table serves only for the preselection of the drive. An accurate calculation takes place after publication of the design information. Please you use the form „Form for projection of elevator gear units“ (page 11).

suspension 1:1

shaft efficiency = 84%
sound pressure level in 1 m distance < 65 dB(A)
acoustic measurement according to DIN 45635-23-KL3

Nutzlast payload Q [kg]	Masse Fahrkorb car weight max. [kg]	Geschwindigkeit speed v [m/s]	Einstelldrehzahl setting speed n [min ⁻¹]	Getriebetyp gear type	Treibscheibe traction sheave		Motor motor	
					ø [mm]	n x ø Seil/rope max. [mm]	P [kW]	I [A]
320	700	0,63	1360	SS 80.1 x 37,3	330	6 x 8	2,2	4,9
		0,8	1468	SS 80.1 x 31,7	330	6 x 8	2,2	4,9
		1,0	1377	SS 80.1 x 23,8	330	6 x 8	3,0	6,7
		1,6	1417	SS 80.1 x 15,3	330	6 x 8	4,0	8,8
		0,63	1405	SS 100 x 46,7	400	6 x 10	2,2	4,9
		0,8	1486	SS 100 x 38,9	400	6 x 10	2,2	4,9
		1,0	1346	SS 100 x 28,2	400	6 x 10	3,0	6,7
		1,6	1474	SS 100 x 19,3	400	6 x 10	4,0	8,8
450	800	0,63	1418	SS 100 x 38,9	330	6 x 8	2,2	4,9
		0,8	1306	SS 100 x 28,2	330	6 x 8	3,0	6,7
		1,0	1458	SS 100 x 25,2	330	6 x 8	4,0	8,8
		1,6	1472	SS 100 x 15,9	330	6 x 8	5,5	12,1
		0,63	1405	SS 100 x 46,7	400	6 x 10	2,2	4,9
		0,8	1486	SS 100 x 38,9	400	6 x 10	3,0	6,7
		1,0	1346	SS 100 x 28,2	400	6 x 10	4,0	8,8
		1,6	1474	SS 100 x 19,3	400	6 x 10	5,5	12,1
		0,63	1349	SS 100 x 58,3	520	6 x 12	2,2	4,9
		0,8	1372	SS 100 x 46,7	520	6 x 12	3,0	6,7
		1,0	1429	SS 100 x 38,9	520	6 x 12	4,0	8,8
		1,6	1481	SS 100 x 25,2	520	6 x 12	5,5	12,1
630	1100	0,63	1418	SS 100 x 38,9	330	6 x 8	3,0	6,7
		0,8	1306	SS 100 x 28,2	330	6 x 8	4,0	8,8
		1,0	1458	SS 100 x 25,2	330	6 x 8	5,5	12,1
		1,6	1472	SS 100 x 15,9	330	6 x 8	7,5	15,0
		0,63	1405	SS 100 x 46,7	400	6 x 10	3,0	6,7
		0,8	1486	SS 100 x 38,9	400	6 x 10	4,0	8,8
		1,0	1346	SS 100 x 28,2	400	6 x 10	5,5	12,1
		1,6	1474	SS 100 x 19,3	400	6 x 10	7,5	15,0
		0,63	1312	SS 125 x 56,7	520	6 x 12	4,0	8,8
		0,8	1454	SS 125 x 49,5	520	6 x 12	4,0	8,8
		1,0	1436	SS 125 x 39,1	520	6 x 12	5,5	12,1
		1,6	1487	SS 125 x 25,3	520	6 x 12	7,5	15,0

Auswahltable / Selection table

Stirnrad-Schneckengetriebe

Spur-worm gear

Aufhängung 1:1

Schachtwirkungsgrad = 84%

Schalldruckpegel in 1 m Abstand < 65 dB(A)

Geräuschmessung nach DIN 45635-23-KL3

suspension 1:1

shaft efficiency = 84%

sound pressure level in 1 m distance < 65 dB(A)

acoustic measurement according to DIN 45635-23-KL3

Nutzlast payload Q [kg]	Masse Fahrkorb car weight max. [kg]	Geschwindigkeit speed v [m/s]	Einstelldrehzahl setting speed n [min ⁻¹]	Getriebetyp gear type	Treibscheibe traction sheave		Motor motor	
					ø [mm]	n x ø Seil/rope max. [mm]	P [kW]	I [A]
800	1600	0,63	1426	SS 125 x 39,1	330	9 x 8	4,0	8,8
		0,8	1486	SS 125 x 32,1	330	9 x 8	5,5	12,1
		1,0	1464	SS 125 x 25,3	330	9 x 8	7,5	15,0
		1,6	1454	SS 125 x 15,7	330	9 x 8	9,2	19,5
		0,63	1489	SS 125 x 49,5	400	6 x 10	4,0	8,8
		0,8	1494	SS 125 x 39,1	400	6 x 10	5,5	12,1
		1,0	1447	SS 125 x 30,3	400	6 x 10	7,5	15,0
		1,6	1444	SS 125 x 18,9	400	6 x 10	9,2	19,5
		0,63	1312	SS 125 x 56,7	520	6 x 12	5,5	12,1
		0,8	1454	SS 125 x 49,5	520	6 x 12	5,5	12,1
		1,0	1436	SS 125 x 39,1	520	6 x 12	7,5	15,0
		1,6	1487	SS 125 x 25,3	520	6 x 12	9,2	19,5
1000	1650	0,63	1426	SS 125 x 39,1	330	9 x 8	5,5	12,1
		0,8	1486	SS 125 x 32,1	330	9 x 8	7,5	15,0
		1,0	1464	SS 125 x 25,3	330	9 x 8	7,5	15,0
		1,6	1454	SS 125 x 15,7	330	9 x 8	11,0	21,0
		0,63	1489	SS 125 x 49,5	400	6 x 10	5,5	12,1
		0,8	1494	SS 125 x 39,1	400	6 x 10	7,5	15,0
		1,0	1447	SS 125 x 30,3	400	6 x 10	7,5	15,0
		1,6	1444	SS 125 x 18,9	400	6 x 10	11,0	21,0
		0,63	1421	SS 160 x 61,4	520	6 x 12	5,5	12,1
		0,8	1504	SS 160 x 51,2	520	6 x 12	7,5	15,0
		1,0	1410	SS 160 x 38,4	520	6 x 12	7,5	15,0
		1,6	1522	SS 160 x 25,9	520	6 x 12	11,0	21,0
1250	2000	0,63	1369	SS 160 x 51,2	450	8 x 11	7,5	15,0
		1,0	1583	SS 160 x 37,3	450	8 x 11	11,0	21,0
		1,6	1609	SS 160 x 23,7	450	8 x 11	15,0	28,0
		0,63	1421	SS 160 x 61,4	520	8 x 12	7,5	15,0
		0,8	1504	SS 160 x 51,2	520	8 x 12	7,5	15,0
		1,0	1370	SS 160 x 37,3	520	8 x 12	11,0	21,0
1600	2800	1,6	1522	SS 160 x 25,9	520	8 x 12	15,0	28,0
		0,63	974	SS 250 x 51,8	640	7 x 16	17,0	32,0
		0,8	959	SS 250 x 40,2	640	7 x 16	17,0	32,0
		1,0	911	SS 250 x 30,5	640	7 x 16	17,0	32,0
		1,6	1458	SS 250 x 30,5	640	7 x 16	22,0	40,0
		0,63	878	SS 250 x 58,4	800	7 x 16	17,0	32,0
2000	3000	0,8	989	SS 250 x 51,8	800	7 x 16	17,0	32,0
		1,0	959	SS 250 x 40,2	800	7 x 16	17,0	32,0
		1,6	1534	SS 250 x 40,2	800	7 x 16	22,0	40,0
		0,63	974	SS 250 x 51,8	640	7 x 16	17,0	32,0
		0,8	959	SS 250 x 40,2	640	7 x 16	17,0	32,0
		1,0	911	SS 250 x 30,5	640	7 x 16	17,0	32,0
2500	3300	1,6	1458	SS 250 x 30,5	640	7 x 16	25,0	46,0
		0,63	878	SS 250 x 58,4	800	7 x 16	17,0	32,0
		0,8	989	SS 250 x 51,8	800	7 x 16	17,0	32,0
		1,0	959	SS 250 x 40,2	800	7 x 16	17,0	32,0
		1,6	1534	SS 250 x 40,2	800	7 x 16	25,0	46,0
		0,63	974	SS 250 x 51,8	640	7 x 16	17,0	32,0
2500	3300	0,8	959	SS 250 x 40,2	640	7 x 16	17,0	32,0
		1,0	1351	SS 250 x 45,3	640	7 x 16	22,0	40,0
		1,6	1458	SS 250 x 30,5	640	7 x 16	30,0	55,0
		0,63	878	SS 250 x 58,4	800	7 x 16	17,0	32,0
		0,8	989	SS 250 x 51,8	800	7 x 16	17,0	32,0
		1,0	1394	SS 250 x 58,4	800	7 x 16	22,0	40,0
		1,6	1534	SS 250 x 40,2	800	7 x 16	30,0	55,0

Auswahltabelle / Selection table

Schnecken-Stirnradgetriebe

Worm-spur gear

Aufhängung 1:1

Schachtwirkungsgrad = 84%

Schalldruckpegel in 1 m Abstand < 60 dB(A)

Geräuschmessung nach DIN 45635-23-KL3

suspension 1:1

shaft efficiency = 84%

sound pressure level in 1 m distance < 60 dB(A)

acoustic measurement according to DIN 45635-23-KL3

Nutzlast payload Q [kg]	Masse Fahrkorb car weight max. [kg]	Geschwindigkeit speed v [m/s]	Einstelldrehzahl setting speed n [min ⁻¹]	Getriebetyp gear type	Treibscheibe traction sheave		Motor motor	
					ø [mm]	n x ø Seil / rope max. [mm]	P [kW]	I [A]
320	700	0,63	1360	SST 97 x 37,3	330	6 x 8	2,2	4,9
		0,8	1417	SST 97 x 30,6	330	6 x 8	2,2	4,9
		1,0	1401	SST 97 x 24,2	330	6 x 8	3,0	6,7
		1,6	1408	SST 97 x 15,2	330	6 x 8	4,0	8,8
		0,63	1396	SST 118 x 46,4	400	6 x 10	2,2	4,9
		0,8	1490	SST 118 x 39,0	400	6 x 10	2,2	4,9
		1,0	1361	SST 118 x 28,5	400	6 x 10	3,0	6,7
		1,6	1451	SST 118 x 19,0	400	6 x 10	4,0	8,8
450	800	0,63	1422	SST 118 x 39,0	330	6 x 8	2,2	4,9
		0,8	1320	SST 118 x 28,5	330	6 x 8	3,0	6,7
		1,0	1447	SST 118 x 25,0	330	6 x 8	4,0	8,8
		1,6	1546	SST 118 x 16,7	330	6 x 8	5,5	12,1
		0,63	1396	SST 118 x 46,4	400	6 x 10	2,2	4,9
		0,8	1490	SST 118 x 39,0	400	6 x 10	3,0	6,7
		1,0	1361	SST 118 x 28,5	400	6 x 10	4,0	8,8
		1,6	1451	SST 118 x 19,0	400	6 x 10	5,5	12,1
		0,63	1319	SST 118 x 57,0	520	6 x 12	2,2	4,9
		0,8	1363	SST 118 x 46,4	520	6 x 12	3,0	6,7
1,0	1432	SST 118 x 39,0	520	6 x 12	4,0	8,8		
1,6	1469	SST 118 x 25,0	520	6 x 12	5,5	12,1		
630	1100	0,63	1422	SST 118 x 39,0	330	6 x 8	3,0	6,7
		0,8	1320	SST 118 x 28,5	330	6 x 8	4,0	8,8
		1,0	1447	SST 118 x 25,0	330	6 x 8	5,5	12,1
		1,6	1546	SST 118 x 16,7	330	6 x 8	7,5	15,0
		0,63	1396	SST 118 x 46,4	400	6 x 10	3,0	6,7
		0,8	1490	SST 118 x 39,0	400	6 x 10	4,0	8,8
		1,0	1361	SST 118 x 28,5	400	6 x 10	5,5	12,1
		1,6	1451	SST 118 x 19,0	400	6 x 10	7,5	15,0
		0,63	1277	SST 150 x 55,2	520	6 x 12	4,0	8,8
		0,8	1449	SST 150 x 49,3	520	6 x 12	4,0	8,8
		1,0	1388	SST 150 x 37,8	520	6 x 12	5,5	12,1
1,6	1446	SST 150 x 24,6	520	6 x 12	7,5	15,0		
800	1600	0,63	1378	SST 150 x 37,8	330	6 x 8	4,0	8,8
		0,8	1403	SST 150 x 30,3	330	6 x 8	5,5	12,1
		1,0	1424	SST 150 x 24,6	330	6 x 8	7,5	15,0
		1,6	1519	SST 150 x 16,4	330	6 x 8	9,2	19,5
		0,63	1483	SST 150 x 49,3	400	6 x 10	4,0	8,8
		0,8	1444	SST 150 x 37,8	400	6 x 10	5,5	12,1
		1,0	1447	SST 150 x 30,3	400	6 x 10	7,5	15,0
		1,6	1406	SST 150 x 18,4	400	6 x 10	9,2	19,5
		0,63	1277	SST 150 x 55,2	520	6 x 12	5,5	12,1
		0,8	1449	SST 150 x 49,3	520	6 x 12	5,5	12,1
		1,0	1388	SST 150 x 37,8	520	6 x 12	7,5	15,0
		1,6	1446	SST 150 x 24,6	520	6 x 12	9,2	19,5
1000	1650	0,63	1378	SST 150 x 37,8	330	6 x 8	5,5	12,1
		0,8	1403	SST 150 x 30,3	330	6 x 8	7,5	15,0
		1,0	1424	SST 150 x 24,6	330	6 x 8	7,5	15,0
		1,6	1519	SST 150 x 16,4	330	6 x 8	11,0	21,0
		0,63	1483	SST 150 x 49,3	400	6 x 10	5,5	12,1
		0,8	1444	SST 150 x 37,8	400	6 x 10	7,5	15,0
		1,0	1447	SST 150 x 30,3	400	6 x 10	7,5	15,0
		1,6	1406	SST 150 x 18,4	400	6 x 10	11,0	21,0

Auswahltable / Selection table

Stirnrad-Schneckengetriebe

Spur-worm gear

Aufhängung 2:1

Schachtwirkungsgrad = 84%

Schalldruckpegel in 1 m Abstand < 65 dB(A)

Geräuschmessung nach DIN 45635-23-KL3

suspension 2:1

shaft efficiency = 84%

sound pressure level in 1 m distance < 65 dB(A)

acoustic measurement according to DIN 45635-23-KL3

Nutzlast payload Q [kg]	Masse Fahrkorb car weight max. [kg]	Geschwindigkeit speed v [m/s]	Einstelldrehzahl setting speed n [min ⁻¹]	Getriebetyp gear type	Treibscheibe traction sheave		Motor motor	
					ø [mm]	n x ø Seil / rope max. [mm]	P [kW]	I [A]
320	700	0,63	1342	SS 80.1 x 18,4	330	6 x 8	2,2	4,9
		0,8	1417	SS 80.1 x 15,3	330	6 x 8	2,2	4,9
		1,0	1377	SS 80.1 x 11,9	330	6 x 8	3,0	6,7
		1,6	1426	SS 80.1 x 7,7	330	6 x 8	4,0	8,8
		0,63	1432	SS 80.1 x 23,8	400	6 x 10	2,2	4,9
		0,8	1406	SS 80.1 x 18,4	400	6 x 10	2,2	4,9
		1,0	1461	SS 80.1 x 15,3	400	6 x 10	3,0	6,7
		1,6	1406	SS 80.1 x 9,2	400	6 x 10	4,0	8,8
450	800	0,63	1342	SS 80.1 x 18,4	330	6 x 8	2,2	4,9
		0,8	1417	SS 80.1 x 15,3	330	6 x 8	3,0	6,7
		1,0	1377	SS 80.1 x 11,9	330	6 x 8	4,0	8,8
		1,6	1463	SS 100 x 7,9	330	6 x 8	5,5	12,1
		0,63	1432	SS 80.1 x 23,8	400	6 x 10	2,2	4,9
		0,8	1406	SS 80.1 x 18,4	400	6 x 10	3,0	6,7
		1,0	1461	SS 80.1 x 15,3	400	6 x 10	4,0	8,8
		1,6	1482	SS 100 x 9,7	400	6 x 10	5,5	12,1
630	1100	0,63	1342	SS 80.1 x 18,4	330	6 x 8	4,0	8,8
		0,8	1417	SS 80.1 x 15,3	330	6 x 8	4,0	8,8
		1,0	1458	SS 100 x 12,6	330	6 x 8	5,5	12,1
		1,6	1463	SS 100 x 7,9	330	6 x 8	7,5	15,0
		0,63	1516	SS 100 x 25,2	400	6 x 10	3,0	6,7
		0,8	1474	SS 100 x 19,3	400	6 x 10	4,0	8,8
		1,0	1518	SS 100 x 15,9	400	6 x 10	5,5	12,1
		1,6	1482	SS 100 x 9,7	400	6 x 10	7,5	15,0
800	1600	0,63	1407	SS 100 x 19,3	330	6 x 8	4,0	8,8
		0,8	1472	SS 100 x 15,9	330	6 x 8	5,5	12,1
		1,0	1458	SS 100 x 12,6	330	6 x 8	7,5	15,0
		1,6	1463	SS 125 x 8,2	330	6 x 8	9,2	19,5
		0,63	1516	SS 100 x 25,2	400	6 x 10	4,0	8,8
		0,8	1474	SS 100 x 19,3	400	6 x 10	5,5	12,1
		1,0	1518	SS 100 x 15,9	400	6 x 10	7,5	15,0
		1,6	1558	SS 125 x 10,2	400	6 x 10	9,2	19,5
1000	1650	0,63	1407	SS 100 x 19,3	330	6 x 8	5,5	12,1
		0,8	1472	SS 100 x 15,9	330	6 x 8	7,5	15,0
		1,0	1458	SS 100 x 12,6	330	6 x 8	7,5	15,0
		1,6	1519	SS 125 x 8,2	330	6 x 8	11,0	21,0
		0,63	1516	SS 100 x 25,2	400	6 x 10	5,5	12,1
		0,8	1474	SS 100 x 19,3	400	6 x 10	7,5	15,0
		1,0	1518	SS 100 x 15,9	400	6 x 10	7,5	15,0
		1,6	1558	SS 125 x 10,2	400	6 x 10	11,0	21,0
1250	2000	0,63	1522	SS 125 x 25,3	400	6 x 10	7,5	15,0
		0,8	1444	SS 125 x 18,9	400	6 x 10	7,5	15,0
		1,0	1499	SS 125 x 15,7	400	6 x 10	11,0	21,0
		1,6	1558	SS 125 x 10,2	400	6 x 10	15,0	28,0
		0,63	1486	SS 125 x 32,1	520	6 x 12	7,5	15,0
		0,8	1487	SS 125 x 25,3	520	6 x 12	7,5	15,0
		1,0	1388	SS 125 x 18,9	520	6 x 12	11,0	21,0
		1,5	1521	SS 125 x 13,8	520	6 x 12	15,0	28,0
1,6	1548	SS 125 x 11,4	450	6 x 11	15,0	28,0		

Auswahltabelle / Selection table

Stirnrad-Schneckengetriebe

Spur-worm gear

Aufhängung 2:1

Schachtwirkungsgrad = 84%

Schalldruckpegel in 1 m Abstand < 65 dB(A)

Geräuschmessung nach DIN 45635-23-KL3

suspension 2:1

shaft efficiency = 84%

sound pressure level in 1 m distance < 65 dB(A)

acoustic measurement according to DIN 45635-23-KL3

Nutzlast payload Q [kg]	Masse Fahrkorb car weight max. [kg]	Geschwindigkeit speed v [m/s]	Einstelldrehzahl setting speed n [min ⁻¹]	Getriebetyp gear type	Treibscheibe traction sheave		Motor motor	
					ø [mm]	n x ø Seil / rope max. [mm]	P [kW]	I [A]
1600	2800	0,63	1522	SS 125 x 25,3	400	6 x 10	7,5	15,0
		0,8	1444	SS 125 x 18,9	400	6 x 10	11,0	21,0
		1,0	1499	SS 125 x 15,7	400	6 x 10	15,0	28,0
		1,6	1558	SS 160 x 10,2	400	6 x 10	22,0	42,0
		0,63	1486	SS 125 x 32,1	520	6 x 12	7,5	15,0
		0,8	1487	SS 125 x 25,3	520	6 x 12	11,0	21,0
		1,0	1388	SS 125 x 18,6	520	6 x 12	15,0	28,0
		1,5	1499	SS 160 x 13,6	520	6 x 12	18,5	34,5
		1,6	1508	SS 160 x 14,8	600	6 x 12	22,0	42,0
2000	3000	0,63	1353	SS 125 x 25,3	450	8 x 11	11,0	21,0
		0,8	1283	SS 125 x 18,9	450	8 x 11	15,0	28,0
		1,0	1392	SS 160 x 16,4	450	8 x 11	15,0	28,0
		1,6	1385	SS 160 x 10,2	450	8 x 11	28,0	56,0
		0,63	1462	SS 160 x 31,6	520	8 x 12	11,0	21,0
		0,8	1522	SS 160 x 25,9	520	8 x 12	15,0	28,0
		1,0	1447	SS 160 x 19,7	520	8 x 12	15,0	28,0
		1,5	1499	SS 160 x 13,6	520	8 x 12	22,0	42,0
		1,6	1508	SS 160 x 14,8	600	7 x 13	28,0	56,0
2500	3300	0,63	1462	SS 160 x 31,6	520	8 x 12	15,0	28,0
		0,8	1522	SS 160 x 25,9	520	8 x 12	15,0	28,0
		1,0	1447	SS 160 x 19,7	520	8 x 12	18,5	34,5
		1,6	1544	SS 250 x 13,1	520	8 x 12	30,0	55,0
		0,63	1496	SS 160 x 37,3	600	7 x 13	15,0	28,0
		0,8	1609	SS 160 x 31,6	600	7 x 13	15,0	28,0
		1,0	1509	SS 160 x 23,7	600	7 x 13	18,5	34,5
		1,6	1556	SS 250 x 15,3	600	7 x 13	30,0	55,0
		3000	4400	0,63	974	SS 250 x 25,9	640	7 x 16
0,8	1538			SS 250 x 32,2	640	7 x 16	22,0	40,0
1,0	1350			SS 250 x 22,6	640	7 x 16	25,0	46,0
0,63	969			SS 250 x 32,2	800	7 x 16	17,0	32,0
0,8	1534			SS 250 x 40,2	800	7 x 16	22,0	40,0
1,0	1487			SS 250 x 32,2	800	7 x 16	25,0	46,0
4000	5500			0,63	1510	SS 250 x 40,2	640	7 x 16
		0,8	1538	SS 250 x 32,2	640	7 x 16	25,0	46,0
		1,0	1546	SS 250 x 25,9	640	7 x 16	30,0	55,0
		0,63	1558	SS 250 x 51,8	800	7 x 16	22,0	40,0
		0,8	1534	SS 250 x 40,2	800	7 x 16	25,0	46,0
		1,0	1437	SS 250 x 32,2	800	7 x 16	30,0	55,0
		5000	6500	0,63	1510	SS 250 x 40,2	640	7 x 16
0,8	1538			SS 250 x 32,2	640	7 x 16	30,0	55,0
1,0	1546			SS 250 x 25,9	640	7 x 16	37,0	68,0
0,63	1558			SS 250 x 51,8	800	7 x 16	25,0	46,0
0,8	1534			SS 250 x 40,2	800	7 x 16	30,0	55,0
1,0	1537			SS 250 x 32,2	800	7 x 16	37,0	68,0

Auswahltable / Selection table

Schnecken-Stirnradgetriebe

Worm-spur gear

Aufhängung 2:1

Schachtwirkungsgrad = 84%

Schalldruckpegel in 1 m Abstand < 60 dB(A)

Geräuschmessung nach DIN 45635-23-KL3

suspension 2:1

shaft efficiency = 84%

sound pressure level in 1 m distance < 60 dB(A)

acoustic measurement according to DIN 45635-23-KL3

Nutzlast payload Q [kg]	Masse Fahrkorb car weight max. [kg]	Geschwindigkeit speed v [m/s]	Einstelldrehzahl setting speed n [min ⁻¹]	Getriebetyp gear type	Treibscheibe traction sheave		Motor motor	
					ø [mm]	n x ø Seil / rope max. [mm]	P [kW]	I [A]
320	700	0,63	1495	SST 97 x 20,5	330	6 x 8	2,2	4,9
		0,8	1408	SST 97 x 15,2	330	6 x 8	2,2	4,9
		1,0	1389	SST 97 x 12,0	330	6 x 8	3,0	6,7
		1,6	1463	SST 97 x 7,9	330	6 x 8	4,0	8,8
		0,63	1456	SST 97 x 24,2	400	6 x 10	2,2	4,9
		0,8	1375	SST 97 x 18,0	400	6 x 10	2,2	4,9
		1,0	1451	SST 97 x 15,2	400	6 x 10	3,0	6,7
		1,6	1558	SST 97 x 10,2	400	6 x 10	4,0	8,8
450	800	0,63	1495	SST 97 x 20,5	330	6 x 8	2,2	4,9
		0,8	1408	SST 97 x 15,2	330	6 x 8	3,0	6,7
		1,0	1389	SST 97 x 12,0	330	6 x 8	4,0	8,8
		1,6	1500	SST 118 x 8,1	330	6 x 8	5,5	12,1
		0,63	1456	SST 97 x 24,2	400	6 x 10	2,2	4,9
		0,8	1375	SST 97 x 18,0	400	6 x 10	3,0	6,7
		1,0	1451	SST 97 x 15,2	400	6 x 10	4,0	8,8
		1,6	1497	SST 118 x 9,8	400	6 x 10	5,5	12,1
630	1100	0,63	1495	SST 97 x 20,5	330	6 x 8	3,0	6,7
		0,8	1408	SST 97 x 15,2	330	6 x 8	4,0	8,8
		1,0	1401	SST 118 x 12,1	330	6 x 8	5,5	12,1
		1,6	1500	SST 118 x 8,1	330	6 x 8	7,5	15,0
		0,63	1504	SST 118 x 25,0	400	6 x 10	3,0	6,7
		0,8	1451	SST 118 x 19,0	400	6 x 10	4,0	8,8
		1,0	1595	SST 118 x 16,7	400	6 x 10	5,5	12,1
		1,6	1497	SST 118 x 9,8	400	6 x 10	7,5	15,0
800	1600	0,63	1386	SST 118 x 19,0	330	6 x 8	4,0	8,8
		0,8	1546	SST 118 x 16,7	330	6 x 8	5,5	12,1
		1,0	1401	SST 118 x 12,1	330	6 x 8	7,5	15,0
		1,6	1408	SST 150 x 7,6	330	6 x 8	9,2	19,5
		0,63	1504	SST 118 x 25,0	400	6 x 10	4,0	8,8
		0,8	1451	SST 118 x 19,0	400	6 x 10	5,5	12,1
		1,0	1595	SST 118 x 16,7	400	6 x 10	7,5	15,0
		1,6	1543	SST 150 x 10,1	400	6 x 10	9,2	19,5
1000	1650	0,63	1386	SST 118 x 19,0	330	6 x 8	5,5	12,1
		0,8	1546	SST 118 x 16,7	330	6 x 8	7,5	15,0
		1,0	1401	SST 118 x 12,1	330	6 x 8	7,5	15,0
		1,6	1408	SST 150 x 7,6	330	6 x 8	11,0	21,0
		0,63	1504	SST 118 x 25,0	400	6 x 10	5,5	12,1
		0,8	1451	SST 118 x 19,0	400	6 x 10	7,5	15,0
		1,0	1595	SST 118 x 16,7	400	6 x 10	7,5	15,0
		1,6	1543	SST 150 x 10,1	400	6 x 10	11,0	21,0
1250	2000	0,63	1480	SST 150 x 24,6	400	6 x 10	7,5	15,0
		0,8	1406	SST 150 x 18,4	400	6 x 10	7,5	15,0
		1,0	1409	SST 150 x 14,8	400	6 x 10	11,0	21,0
		1,6	1543	SST 150 x 10,1	400	6 x 10	15,0	28,0
		0,63	1402	SST 150 x 30,3	520	6 x 12	7,5	15,0
		0,8	1446	SST 150 x 24,6	520	6 x 12	7,5	15,0
		1,0	1352	SST 150 x 18,4	520	6 x 12	11,0	21,0
		1,4	1518	SST 150 x 14,8	520	6 x 12	15,0	28,0
1,6	1372	SST 150 x 10,1	450	6 x 11	15,0	28,0		
1600	2800	0,63	1480	SST 150 x 24,6	400	6 x 10	7,5	15,0
		0,8	1406	SST 150 x 18,4	400	6 x 10	11,0	21,0
		1,0	1409	SST 150 x 14,8	400	6 x 10	15,0	28,0
		0,63	1402	SST 150 x 30,3	520	6 x 12	7,5	15,0
		0,8	1446	SST 150 x 24,6	520	6 x 12	11,0	21,0
		1,0	1352	SST 150 x 18,4	520	6 x 12	15,0	28,0

Fragebogen zur Projektierung von Aufzugsantrieben

Form for projection of elevator gear units

→ www.gfc-antriebe.de → Produkte → Aufzugsantriebe / Products → Elevator gear units

GFC AntriebsSysteme GmbH

Telefax: +49 (0) 3523 74 142

Absender / company: Projekt / project:

.....

.....

.....

- frequenzgeregelt / work to frequency converter
- Stirnrad-Schneckengetriebemotor - Schalldruckpegel < 65 dB (A) / Spur-worm gear motor unit - noise pressure level < 65 dB (A)
- Schnecken-Stirnradgetriebemotor - Schalldruckpegel < 60 dB (A) / Worm-spur gear motor unit - noise pressure level < 60 dB (A)
- Geräuschmessung nach DIN 45635-23-KL3 / acoustic measurement according to DIN 45635-23-KL3

Stückzahl / number of pieces	Stk / p.	
Nennlast / pay load	kg	
Fahrkorbgewicht / car weight	kg	
Gegengewicht / counterweight	kg	
Nenngeschwindigkeit / speed	ms ⁻¹	
Förderhöhe / delivery height	m	
Aufhängung / suspension		: 1
Anzahl der Umlenkrollen / number of tail	Stk / p.	
... mit gleichsinniger Biegung / of diversion sheaves	Stk / p.	
... mit Wechselbiegung / of inversion sheaves	Stk / p.	
... mittlerer Durchmesser / average diameter	mm	
Umlenkrollen / tail		<input type="checkbox"/> wälzgelagert / antifriction bearing <input type="checkbox"/> gleitgelagert / slide bearing
Seiltyp / type of rope		
Anzahl der Seile / number of rope	Stk / p.	
Seildurchmesser / diameter of rope	mm	
Seilgewichtsausgleich / rope compensation	%	
Treibscheibendurchmesser / traction sheave	mm	
Umschlingungswinkel / arc of contact	°	
Lage des Antriebes / position of the elevator gear unit		<input type="checkbox"/> oben / above <input type="checkbox"/> unten / below <input type="checkbox"/> unten neben / below beside
Treibscheibenlage / position of traction sheave ... vom Motor aus gesehen / ... look from motor		<input type="checkbox"/> links / left <input type="checkbox"/> rechts / right
Netzspannung / voltage		
Netzfrequenz / frequency		
Fahrtzahl / starting per hour Impulszahl / count rate		<input type="checkbox"/> 180 <input type="checkbox"/> 240 <input type="checkbox"/>
Inkrementalgeber / incremental encoder		<input type="checkbox"/> 1024 <input type="checkbox"/>
Ausgangssignal / output signals		<input type="checkbox"/> TTL <input type="checkbox"/> HTL <input type="checkbox"/> 1Vss
Anschlussspannung Bremse / brake voltage		<input type="checkbox"/> 24 VDC <input type="checkbox"/> 205 VDC
Handrad / hand wheel		<input type="checkbox"/> ja / yes <input type="checkbox"/> nein / no
Angebot mit FU / offer about frequency converter		<input type="checkbox"/> ja / yes <input type="checkbox"/> nein / no
gewünschter Liefertermin / delivery date		

Bemerkungen / options:

.....

Abmessungen / Dimensions

SSMVD 80 ... 160

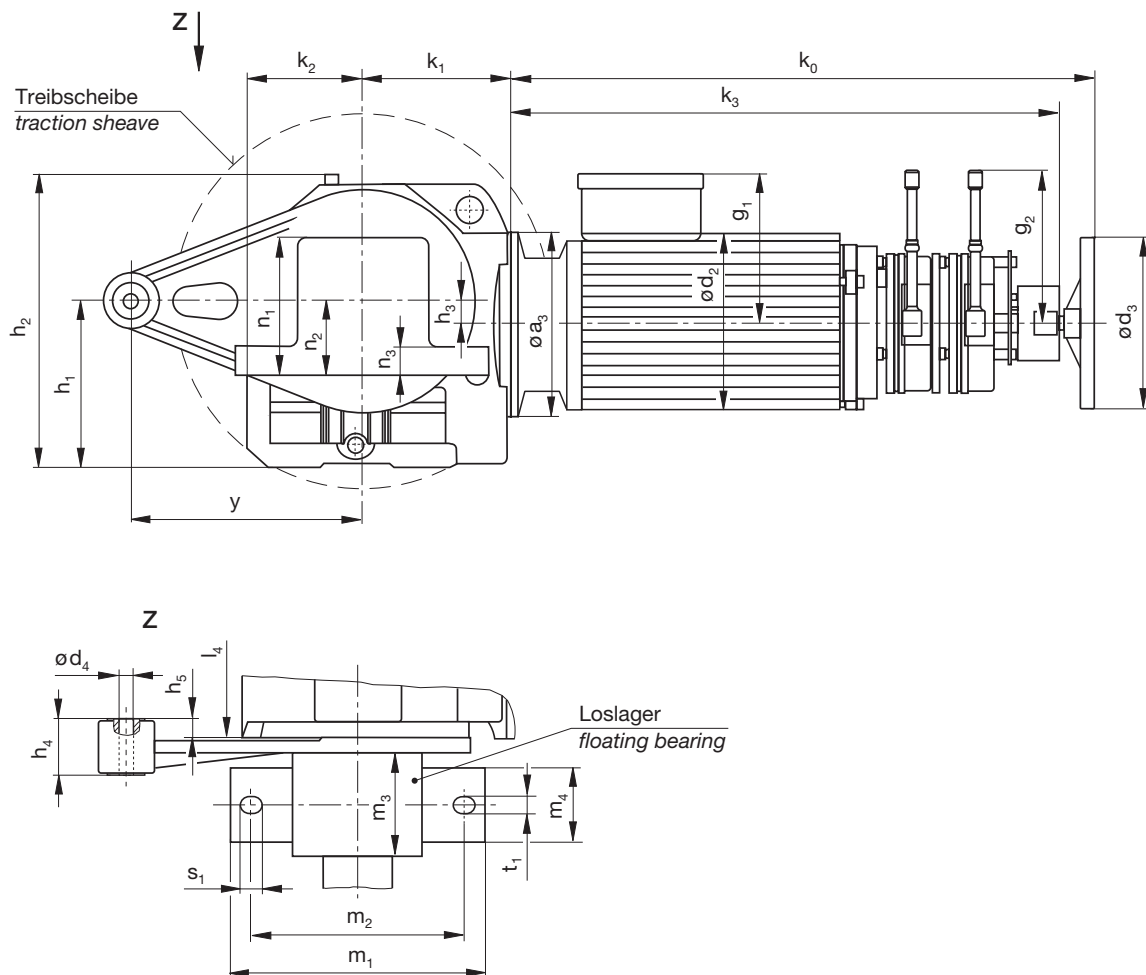

Baugröße size a	für IEC-Motor for IEC motor		øa ₃	≈ k ₀	≈ k ₃	g ₁	g ₂	ød ₂	ød ₃
	kW	Typ							
80	2,2	100 L4	ø160	507	457	145	160	192	200
	3,0	100 LX4		546	495	155	200	213	200
	4,0	112 M4		580	529	155	200	213	200
100	2,2	100 L4	ø200	507	457	145	160	192	200
	3,0	100 LX4		546	495	155	200	213	200
	4,0	112 M4		580	529	155	200	213	200
	5,5	112 MX4		641	583	155	220	213	250
	7,5	132 M4		650	595	214	220	258	250
125	4,0	112 M4	ø250	580	529	155	200	213	200
	5,5	112 MX4		641	583	155	220	213	250
	7,5	132 M4		626	571	214	220	258	250
	9,2	132 M4		646	591	214	220	258	250
	11,0	160 M4		744	683	234	220	310	315
160	15,0	160 L4	ø300	816	748	234	250	310	400
	5,5	112 MX4		641	583	155	220	213	250
	7,5	132 M4		626	571	214	220	258	250
	9,2	132 M4		646	591	214	220	258	250
	11,0	160 M4		717	656	234	220	310	315
	15,0	160 L4		789	721	234	250	310	400
	18,5	180 M4		841	773	254	330	350	400
22,0	180 L4	880	812	254	330	350	400		

Baugröße size a	Getriebe / gear						
	k ₁	k ₂	h ₁	≈ h ₂	h ₃	l ₁	l ₂
80	140	106	145	245	20	497,5	141,5
100	160	125	180	323	26	613,5	170,5
125	195	150	225	392	30	657,0	191,5
160	245	195	280	475	44	709,5	218,0

Maße in mm / measurements in mm

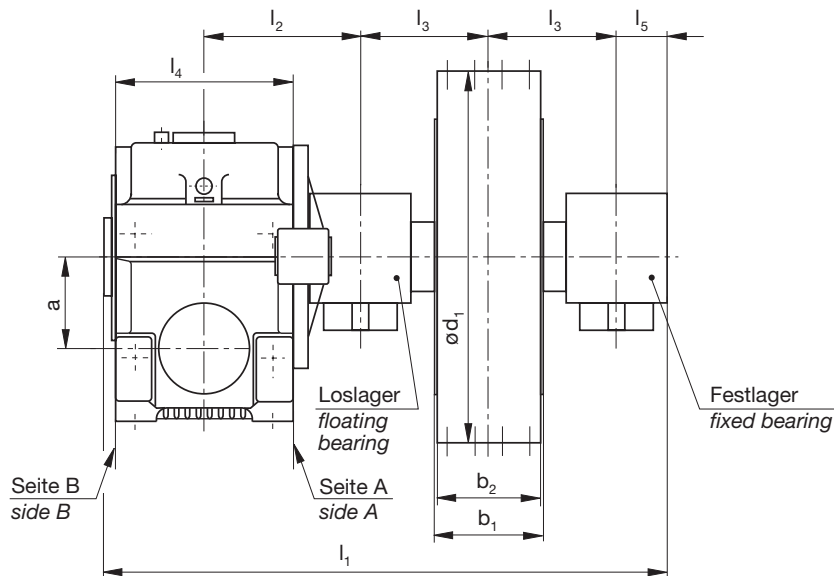

Baugröße size a	Treibscheibe / traction sheave			max. Seil- ϕ max. rope- ϕ
	ϕd_1	b_1	b_2	
80	330	100	110	8
	400	118	114	10
100	330	100	110	8
	400	118	114	10
	520	118	114	13
125	330	158	154	8
	400	118	114	10
	520	118	114	13
	520	158	154	13
160	400	118	114	10
	520	118	114	13
	520	158	154	13

mögliche Anbaustellungen der Drehmomentstütze
possible mounting positions for torque converter bearing

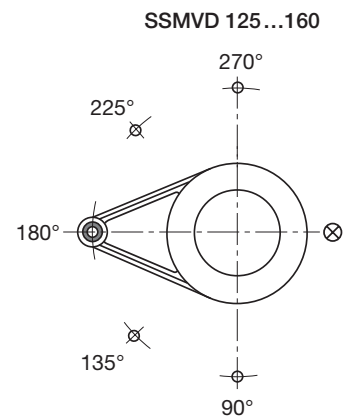
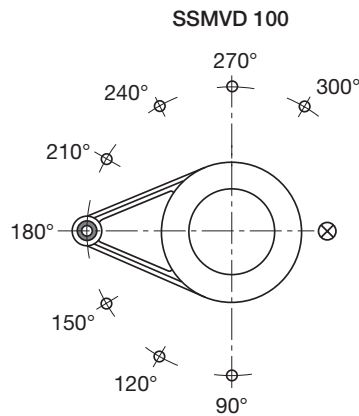
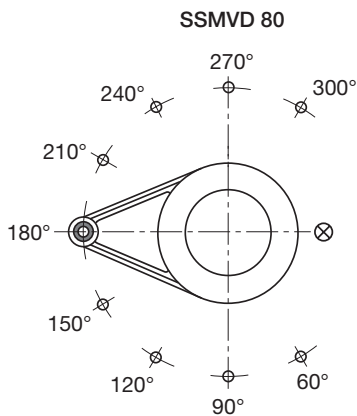

⊗ Motorposition / motor position

Getriebe / gear			Drehmomentstütze torque converter bearing				Stehlager / plummer block bearing								
l_3	l_4	l_5	ϕd_{4H9}	h_4	$\approx h_5$	y	m_1	m_2	m_3	m_4	n_1	n_2	n_3	s_1	t_1
110,5	161	45,0	12	40	12,5	200	205	170	90	60	113	60	25	20	15
139,5	195	55,0	20	70	25,0	250	275	230	110	80	149	80	30	24	18
141,5	207	57,5	20	70	23,0	310	280	230	115	80	155	80	30	24	18
147,0	250	62,5	24	115	54,0	380	320	260	125	90	183	95	32	28	22

Abmessungen / Dimensions

SSMVD 250

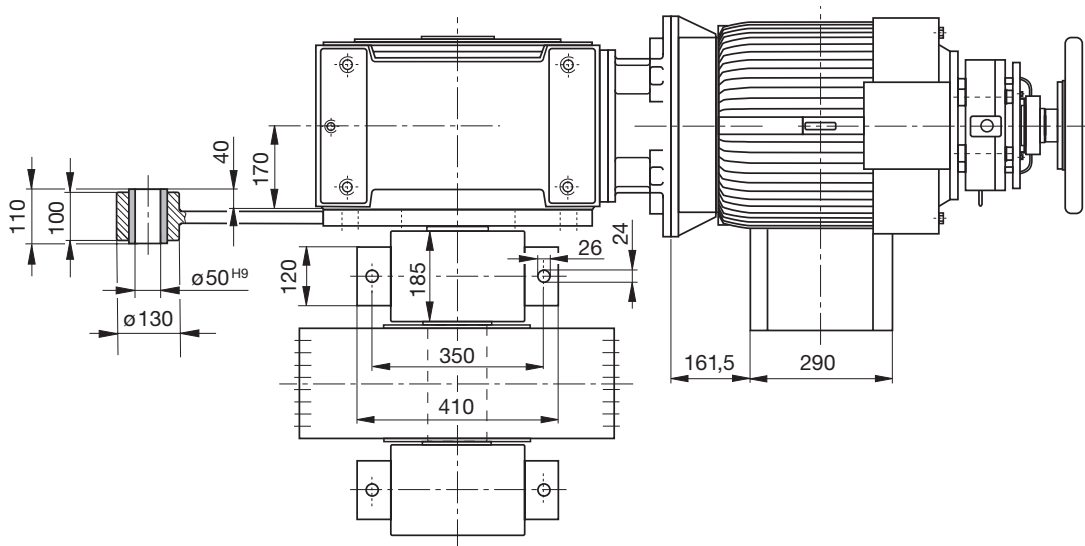
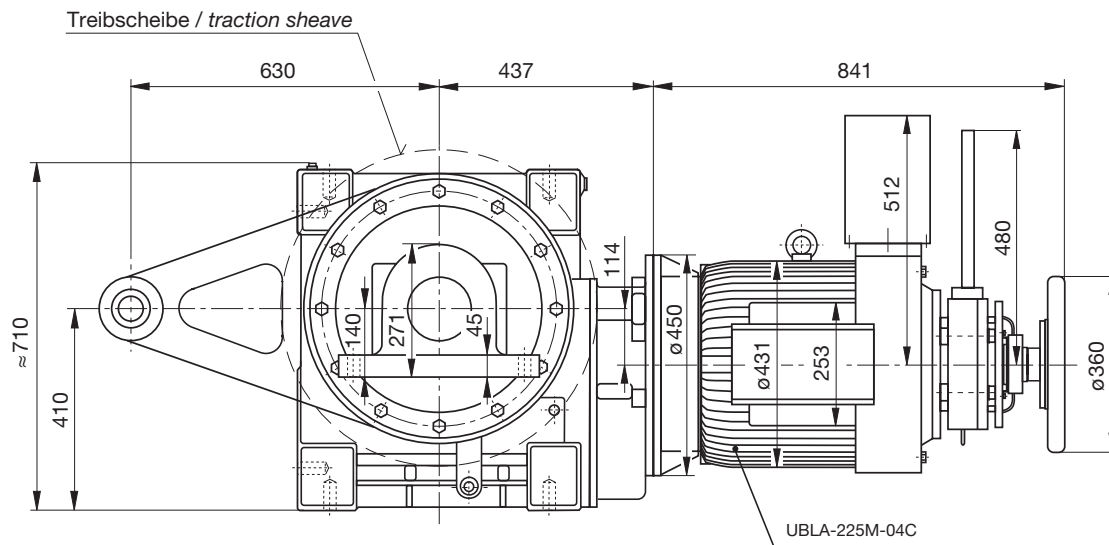

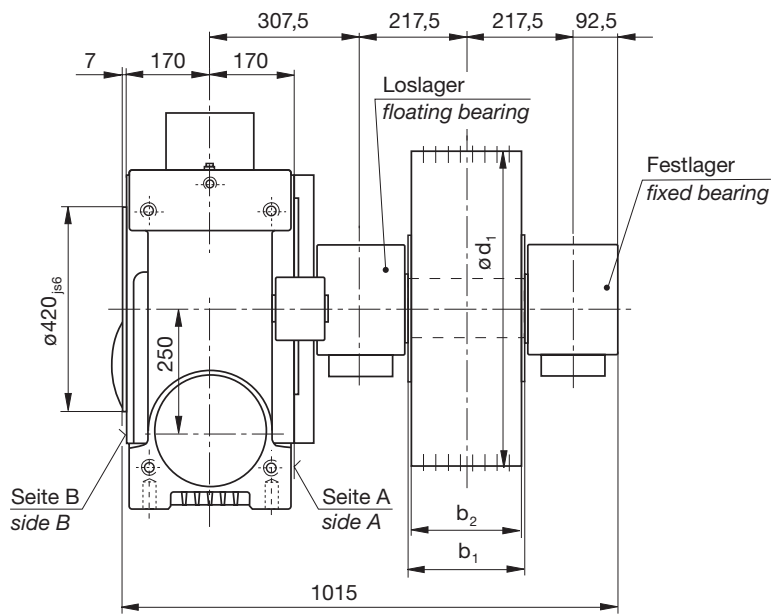

Treibscheibe / traction sheave			
ϕd_1	b_1	b_2	max. Seil- ϕ max. rope- ϕ
600		160	15
640		160	16
640	180	240	16
700		160	16
800		160	20

mögliche Anbaustellungen der Drehmomentstütze
possible mounting positions for torque converter bearing

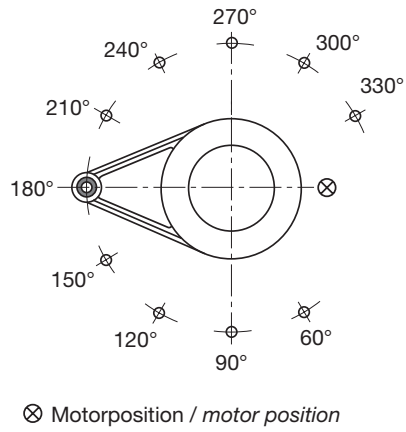

Abmessungen / Dimensions

SSTKVD 97 ... 150

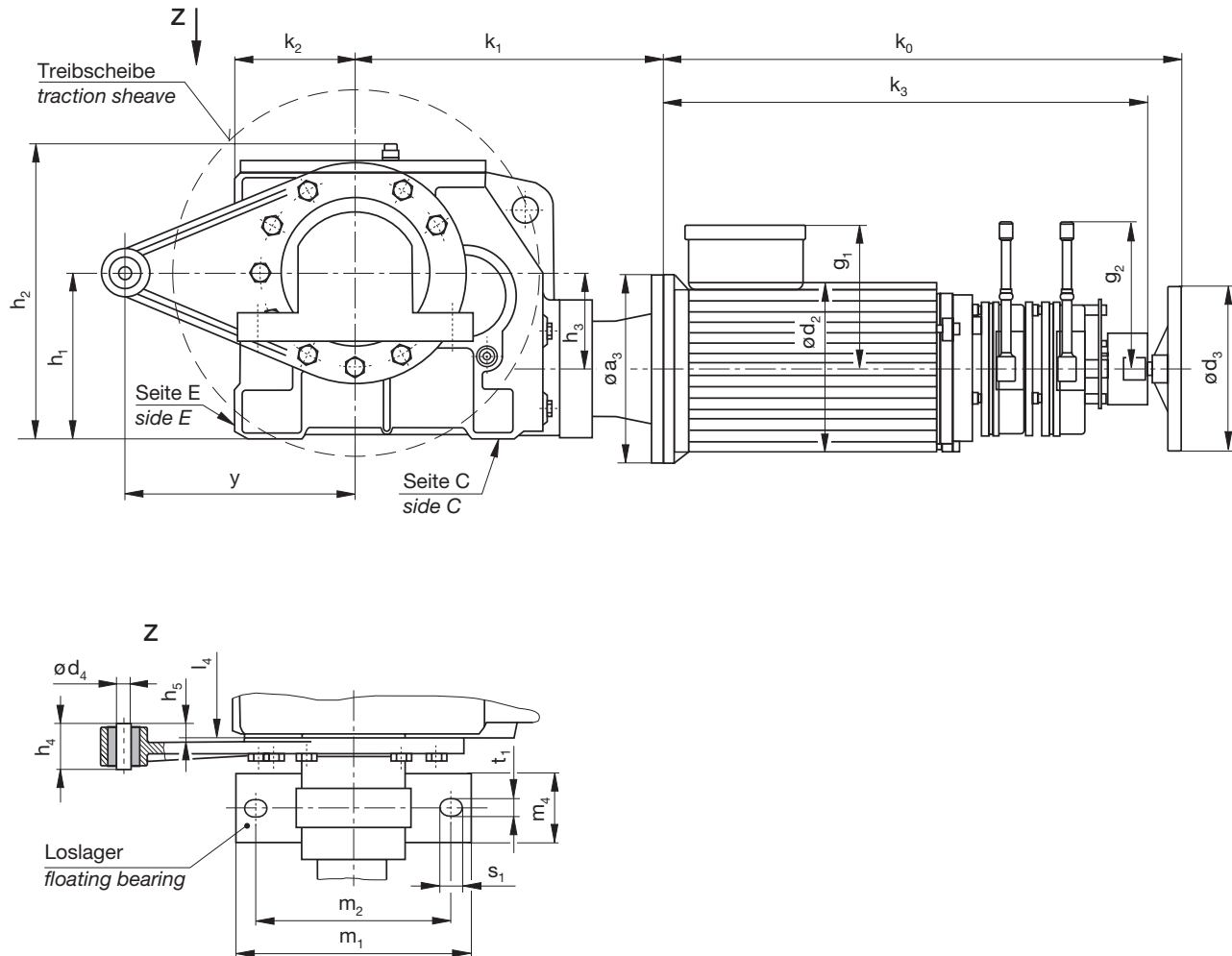

Baugröße size a	für IEC-Motor for IEC motor		øa ₃	≈k ₀	≈k ₃	g ₁	g ₂	ød ₂	ød ₃
	kW	Typ							
97	2,2	100 L4	ø160	468	418	145	160	192	200
	3,0	100 LX4		503	452	155	200	213	200
	4,0	112 M4		537	486	155	200	213	200
118	2,2	100 L4	ø200	468	418	145	160	192	200
	3,0	100 LX4		503	452	155	200	213	200
	4,0	112 M4		537	486	155	200	213	200
	5,5	112 MX4		598	540	155	220	213	250
	7,5	132 M4		626	571	214	220	258	250
150	4,0	112 M4	ø250	537	486	155	200	213	200
	5,5	112 MX4		598	540	155	220	213	250
	7,5	132 M4		626	571	214	220	258	250
	9,2	132 M4		646	591	214	220	258	250
	11,0	160 M4		744	683	234	220	310	315
	15,0	160 L4		816	748	234	250	310	400

Baugröße size a	Getriebe / gear						
	k ₁	k ₂	h ₁	≈h ₂	h ₃	l ₁	l ₂
97	268	105	145	257	84	497,5	141,5
118	307	125	180	314	100	613,5	170,5
150	408	150	235	404	136	657,0	191,5

Maße in mm / measurements in mm

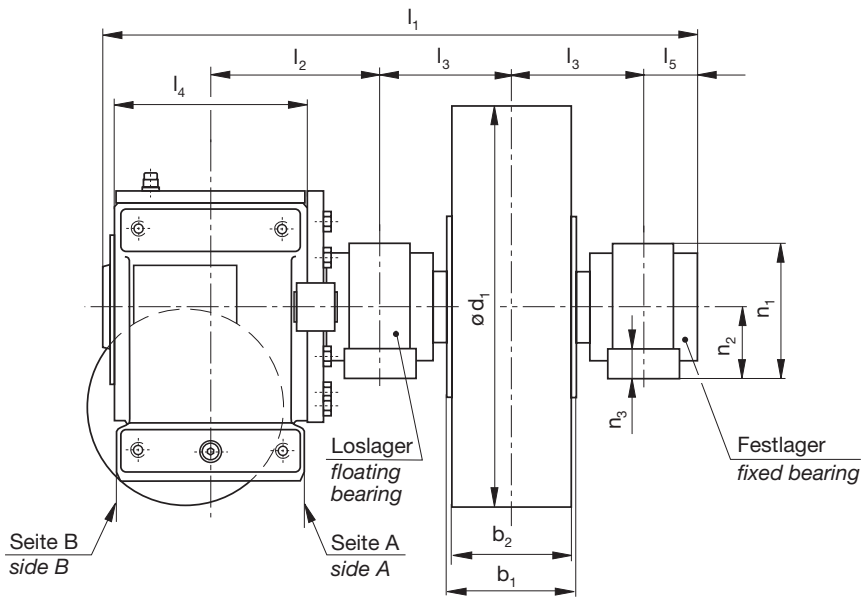

Baugröße size a	Treibscheibe / traction sheave			
	ød ₁	b ₁	b ₂	max. Seil-ø max. rope-ø
97	330	100	110	8
	400	118	114	10
	330	100	110	8
118	400	118	114	10
	520	118	114	13
	330	158	154	8
150	400	118	114	10
	520	118	114	13
	520	158	154	13

mögliche Anbaustellungen der Drehmomentstütze
possible mounting positions for torque converter bearing

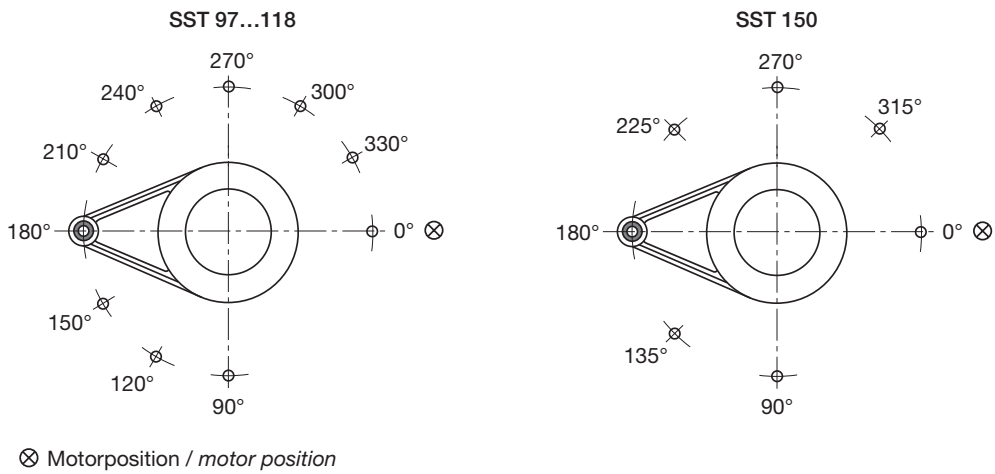

Getriebe / gear			Drehmomentstütze torque converter bearing				Stehlager / plummer block bearing								
l ₃	l ₄	l ₅	ød _{4H9}	h ₄	≈ h ₅	y	m ₁	m ₂	m ₃	m ₄	n ₁	n ₂	n ₃	s ₁	t ₁
110,5	161	45,0	12	40	12,5	200	205	170	90	60	113	60	25	20	15
139,5	195	55,0	20	70	25,0	250	275	230	110	80	149	80	30	24	18
141,5	227	57,5	20	70	23,0	310	280	230	115	80	155	80	30	24	18

Frequenzumrichter

Frequency converter

Sicher Halt

Unidrive SP erfüllt die Norm gemäß EN954-I Kategorie 3 der Maschinenrichtlinie. Dadurch wird das ungewollte Drehen der Motorwelle durch den Antrieb verhindert. Das Sicherheitsmotorschütz kann entfallen und damit Kosten einsparen.

Durchsteckmontage

- Vereinfacht die Wärmeabfuhr
- verringert die Schaltschrankabmessung
- Schutzart IP54/Nema 12 erreichbar

24V DC Elektronikversorgung

Die 24 VDC Einspeisung versorgt die komplette Steuer- elektronik, Encoderauswertung und Kommunikationsmodule. Die Inbetriebnahme und Überwachung ist ohne Netzspannung möglich.

48V DC Versorgung

Die 48 VDC Versorgung erlaubt den Betrieb des Umrichters zur Evakuierung von Aufzügen.

Online Schnittstelle

Frontseitige Modbus RTU Schnittstelle zur Programmierung und Abfrage von

- Unidrive
- Smartcard
- LCD Bedienfeld
- Encoderkonfiguration
- Applikationsmodul

Reliable Stop

Unidrive SP erfüllt die Standardnorm gemäß EN954-I Kategorie 3 der Maschinenrichtlinie. Daher ist die ungewollte Drehung der Motorwelle durch die Antriebseinheit verhindert. Ein Sicherheitsmotorcontactor ist nicht erforderlich. Daher können Kosten gespart werden.

Plug-in assembly

- simplifies heat dissipation
- reduces the control cabinet dimensions
- enclosure protection IP 54/Nema 12 can be achieved

24 V DC electronics supply

The 24 V DC input supplies the entire control electronics, encoder data evaluation and communication modules. Commissioning and monitoring are possible without main power supply.

48V DC supply

The 48V DC supply allows operation of the converter for evacuation of elevators.

Online interface

Front panel Modbus RTU interface for programming and queries from

- unidrive
- smartcard
- LCD control panel
- encoder configuration
- application module



Universeller Encodereingang

Der Unidrive SP kann verschiedene Varianten von Gebersignalen verarbeiten wie:

- Encoder mit Rechtecksignalen
- SinCos Geber

SMARTCARD

Parameterübertragung und -sicherung ist Standard

- steckbar während des Betriebes
- automatische Parametersicherung
- schnelles Kopieren, kostenlos
- 4 komplette Parametersätze
- Applikations-Makros
- Smartcard ist Standardausstattung

Integrierter EMV Netzfilter als Unterbaufilter

Inbetriebnahme-Software

- anschließbar während des Betriebes
- sicher steckbar - bei geschlossener Klemmenabdeckung
- Schnittstelle - Modbus RTU
- Datenaustausch mit der SMARTCARD einfache und sichere Inbetriebnahme und Wartung
- Programmierung der LCD Bedieneinheit

Praktische Kabelmontage

- EMV gerechte Erdung und einfacher, praxisorientierter Anschluss mit geliefertem Zubehör

Konformität ist Standard

- Störfestigkeit nach IEC6100-6-2, IEC61800-3
- Störaussendung nach EN61800-3 mit integriertem Filter
- E/A nach IEC 61131-2
- Programmierung nach IEC61131-3
- Maschinenrichtlinie EN954-I Kat. 3
- „Sicher Halt“ durch BIA zertifiziert
- elektrische Sicherheit EN50178
- erfüllt UL508C
- erfüllt EN81-I für Aufzüge

SM Application Lite

- erforderlich ab 1,5 m/s
- optimale Bremseneinstellung
- Möglichkeit der weggeregelten Direkteinfahrt

Universal encoder input

The Unidrive SP can process various provider signal versions such as:

- encoder with square wave signals
- SinCos encoder

SMARTCARD

Parameter transmission and parameter back-up are standard features

- pluggable during operation
- automatic parameter back-up
- fast copying, free of charge
- 4 complete parameter sets
- application macros
- smartcard as standard equipment

Integrated EMC mains filter as base filter

Software commissioning

- connection during operation possible
- safe plug-in with closed terminal cover
- interface - Modbus RTU
- data exchange with SMARTCARD - simple and safe commissioning and maintenance
- programming of LCD control unit

Convenient cable assembly

- Earthing according to EMC as well as simple and practical connection with supplied accessories.

Conformity is standard

- interference resistance according to IEC6100-6-2, IEC61800-3
- emission according to EN61800-3 with integral filter
- I/O according to IEC 61131-2
- programming according to IEC 61131-3
- machinery directive EN 954-I category 3
- „Reliable Stop“, certified by BIA
- electrical safety EN 50178
- fulfills UL 508C
- fulfills EN 81-I for elevators

SM Application Lite

- required from 1.5 m/s onwards
- optimum setting of brakes
- possibility of position controlled direct operation

Auszug aus der Betriebsanleitung

Extract from the operation instructions

Bitte beachten Sie die vollständige Betriebsanleitung unter: www.gfc-antriebe.de / Dokumentationen / Betriebsanleitung / Aufzugsgetriebe
Please observe the complete operation instructions at: www.gfc-antriebe.de / documents / operating instruction / elevator gear units

Einzelmassen des Aufzugantriebes [kg] / Masses from elevator gear components [kg]

Einzelteil component	SSMVD 80	SSMVD 100	SSMVD 125	SSMVD 160	SSMVD 250	SSTKVD 97	SSTKVD 118	SSTKVD 150
Getriebetyp / Gearbox type	47	83	128	204	660	54	95	157
Motor - 100M4	29	29				29	29	
Motor - 100LX4	39	39				39	39	
Motor - 112M4	46	46	46			46	46	46
Motor - 112MX4		58	58	58			58	58
Motor - 132M4		80	80	80			80	80
Motor - 132L4			98	98				98
Motor - 160M4			135	135				135
Motor - 160L4				160				
Motor - 180M4				217				
Motor - 180L4				240				
Motor - 225ME (17... 45 kW)					420			
Treibscheibe D330/... x 110	28							
Treibscheibe D330/... x 158		50	50				50	50
Treibscheibe D400/... x 118		45	45	45		45	45	45
Treibscheibe D450/... x 118		75	75	75		75	75	75
Treibscheibe D520/... x 118		65	65	65		65	65	65
Treibscheibe D520/... x 158		95	95	95		95	95	95
Treibscheibe D600/... x 118		121	121	121		121	121	121
Treibscheibe D600/... x 138		145	145	145		145	145	145
Treibscheibe D640/... x 160					160			
Treibscheibe D640/... x 240					230			
Treibscheibe D700/... x 160					175			
Treibscheibe D800/... x 160					199			
Treibscheibe D905/... x 160					291			

Treibscheibe / traction sheave

Ölmengen (synthetisches Öl) / Oil quantities (synthetic oil)

Getriebetyp type-size	Betriebslage / operating positions							
	B3		B3 I		B6		B8	
	[l]	[kg]	[l]	[kg]	[l]	[kg]	[l]	[kg]
SSMVD 80	0,9	0,95	3,0	3,1	3,2	3,3	3,0	3,1
SSMVD 100	1,7	1,8	5,4	5,7	5,0	5,3	4,3	4,5
SSMVD 125	4,0	4,2	10,2	10,7	8,6	9,1	7,7	8,1
SSMVD 160	6,0	6,3	21,0	22,1	15,0	15,8	15,0	15,8
SSMVD 250	20,0	21,0	Stufe I: 3,0 Stufe II: 34,0	Stufe I: 3,1 Stufe II: 35,8				
SSTKVD 97	1,8	1,9	3,7	3,9	1,9	2,0	3,0	3,2
SSTKVD 118	3,7	3,9	6,3	6,6	3,0	3,2	6,1	6,4
SSTKVD 150	5,7	6,0	12,0	12,6	5,0	5,3	11,0	11,6

Schmierstoffauswahl / Lubricant table

Schmierstoff lubricant	Kennzeichnung / Marking DIN 51517/3 bzw. DIN 51825	Aral	BP	DEA	Esso	Klüber	Mobil	Shell
Synthetisches Öl synthetic oil	PG 460	Degol GS 460	BP Enersyn SG-XP460	Polydea PGLP460	Glycolube 460	Klübersynth GH6- 460	Mobil Glygoyl HE 460	Tivela Oil 50
Mineralisches Öl mineral oil	CLP 460	BG 460 BMB 460	BP Energol GR-XP460	Falcon CLP460	Spartan EP 460	Klüberoil GEM1-460	Mobilgear 634	Shell Omala Oel 460
Wälzlagerfett anti friction bearing grease		Aralup HLP2	BP Energrease LS-EP2		Beacon EP2	Centoplex	Mobilux EP2	Shell Alvania EP Fett2

Betriebslagen Operating positions

Typ SSMVD 80 ... 160

B3

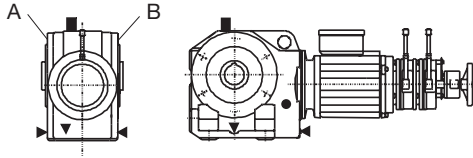

B8

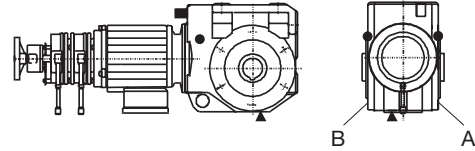

B3I

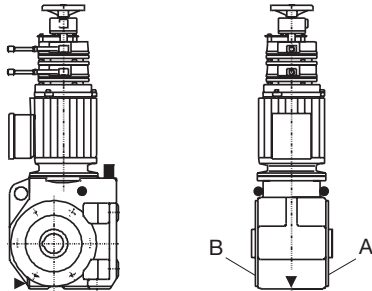

B6

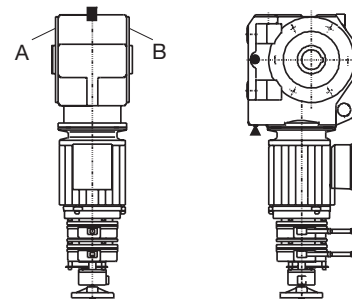

auf Anfrage
on request

Typ SSMVD 250

B3

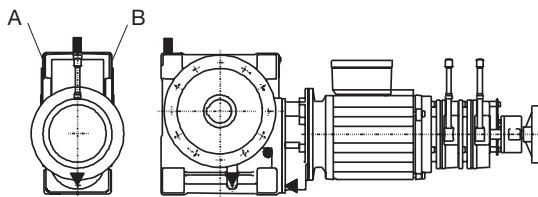

B3I

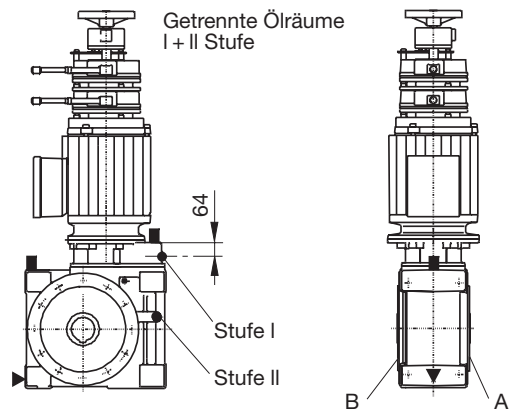

Typ SSTKVD 97 ... 150

B3

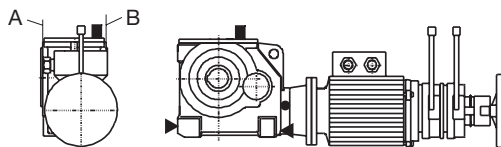

B8

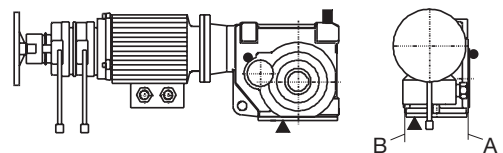

B3I

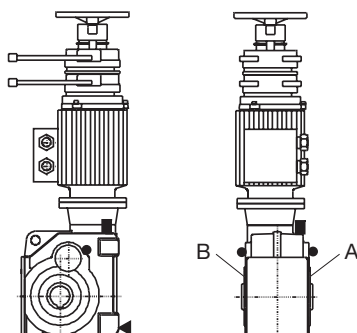

B6

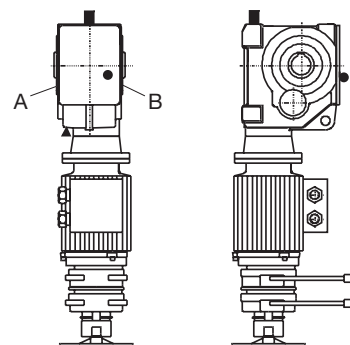

auf Anfrage
on request

■ Entlüfter und Öleinfüllung / ventilation and oil filling

● Ölstand / checking oil level

▲ Ölablass / oil draining

Berechnung der Treibscheibenwelle

Calculation of traction sheave shaft

Berechnungsmethode ... DIN 743 (2000)

Q ... Nutzlast [kg]
 m_{FK} ... Fahrkorbgewicht [kg]
 m_{GG} ... Gegengewicht [kg]
 m_{Seil} ... Seilgewicht [kg]
 m_{CR} ... Seilgewichtsausgleich [kg]
 m_{Trav} ... Hängkabelgewicht [kg]
 Aufhängung
 Umschlingungswinkel [°]

Material Treibscheibe ... 42CrMoS4+QT EN10083-1

calculation method ... DIN 743 (2000)

Q ... service load [kg]
 m_{FK} ... car weight [kg]
 m_{GG} ... counter weight [kg]
 m_{Seil} ... rope weight [kg]
 m_{CR} ... rope compensation [kg]
 m_{Trav} ... weight of trailing cable [kg]
 suspension
 wrap angle [°]

material traction sheave ... 42CrMoS4+QT EN10083-1

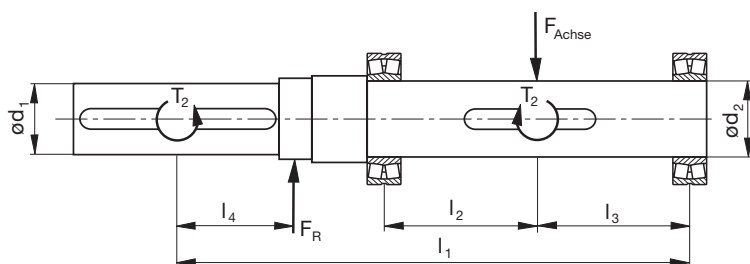

m_{Getr.} ... max. Getriebemasse [kg]
 m_{TR} ... max. Treibscheibenmasse [kg]
 F_{Achse} ... resultierende Achslast [N]
 F_R ... Reaktionskraft Drehmomentstütze [N]
 T₂ ... Abtriebsdrehmoment Getriebemotor [Nm]

m_{Getr.} ... weight gear unit [kg]
 m_{TR} ... weight traction sheave [kg]
 F_{Achse} ... axle load [N]
 F_R ... output torque [N]
 T₂ ... force torque arm [Nm]

Getriebetyp gear type	l ₁ [mm]	l ₂ [mm]	l ₃ [mm]	l ₄ [mm]	d ₁ [mm]	d ₂ [mm]	m _{Getr.} [kg]	m _{TR} [kg]	F _R [N]	T ₂ [Nm]
SSMVD 80	362,5	110,5	110,5	88,0	45	50	78	45	2100	420
SSMVD 100	449,5	139,5	139,5	107,5	60	65	134	65	4000	1000
SSMVD 125	474,5	141,5	141,5	115,5	70	75	251	95	5800	1800
SSMVD 160	512,0	147,0	147,0	128,5	80	85	391	145	7900	3000
SSMVD 250	742,5	217,5	217,5	185,0	115	120	970	200	15800	10000
SSTKVD 97	362,5	110,5	110,5	88,0	45	50	85	45	2500	500
SSTKVD 118	449,5	139,5	139,5	107,5	60	65	146	65	4100	1030
SSTKVD 150	474,5	141,5	141,5	125,5	70	75	280	95	5800	1800

Berechnung der Achslast:
 calculation of axle load:

$$F_{S1} = \frac{(Q + m_{FK} + m_{CR} + m_{Trav}) \cdot 9,81}{r} + m_{TR} \cdot 9,81$$

$$F_{S2} = \frac{m_{GG} \cdot 9,81}{r} + m_{Seil} \cdot 9,81$$

$$F_{Achse} = \sqrt{F_{S1}^2 + F_{S2}^2 - 2 \cdot F_{S1} \cdot F_{S2} \cdot \cos \beta}$$

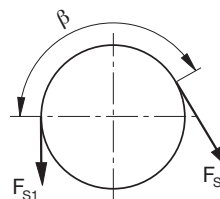

Dauerfestigkeit Treibscheibenwelle / fatigue strength of traction sheave shaft

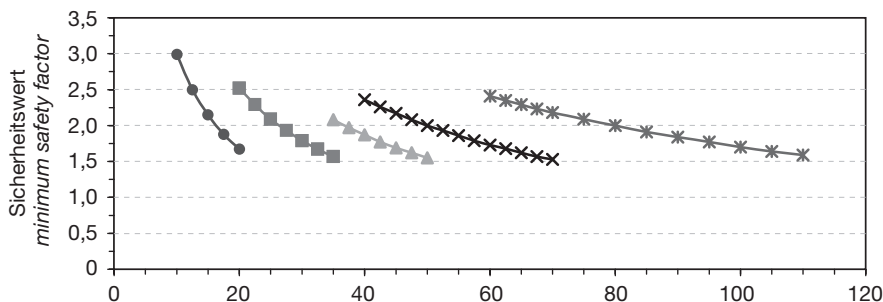

- SSMVD 80 / SSTKVD 97
- ✕ SSMVD 160
- SSMVD 100 / SSTKVD 118
- * SSMVD 250
- ▲ SSMVD 125 / SSTKVD 50

Die Mindestsicherheit für die Treibscheibenwelle ist mit 1,5 festgelegt. Bei der Gestaltung der Aufspannfläche für die Pendelrollenlager sind die Hinweise in der Betriebsanleitung unbedingt zu beachten.

Minimum safety factor for the traction sheave shaft is fixed with 1.5. The references in the manual have to consider for the design of surface clamping from bearing housing.